

**36' IN-LINE STAIR AT RIGHT**  
 $\frac{1}{4}'' = 1'-0''$

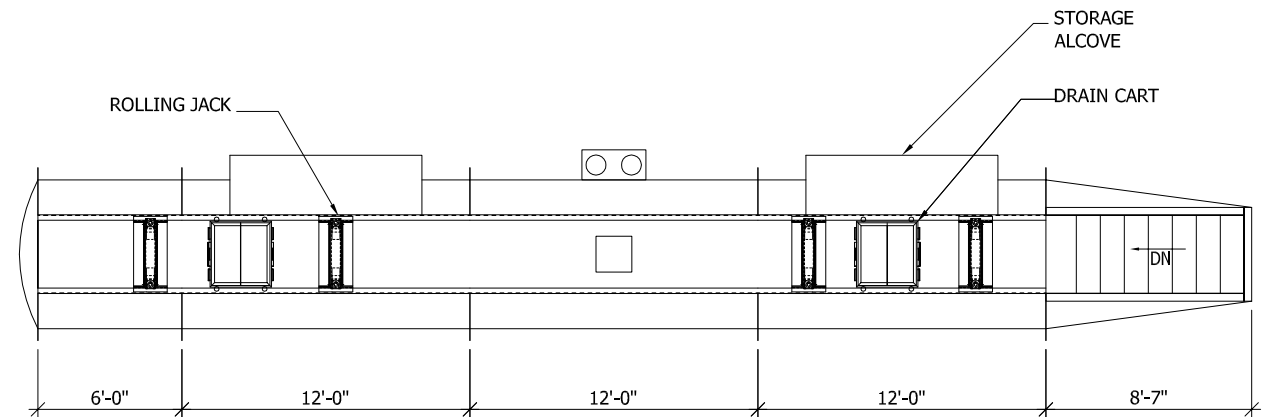

**42' IN-LINE STAIR AT RIGHT**  
 $\frac{1}{4}'' = 1'-0''$

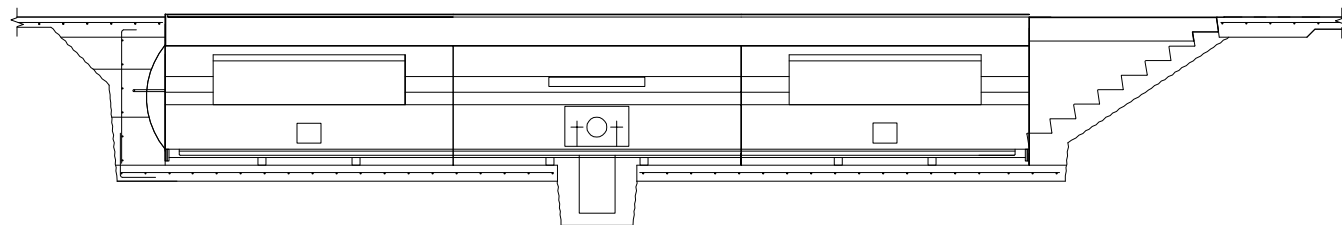

**36' IN-LINE LONGITUDINAL SECTION**  
 $\frac{1}{4}'' = 1'-0''$

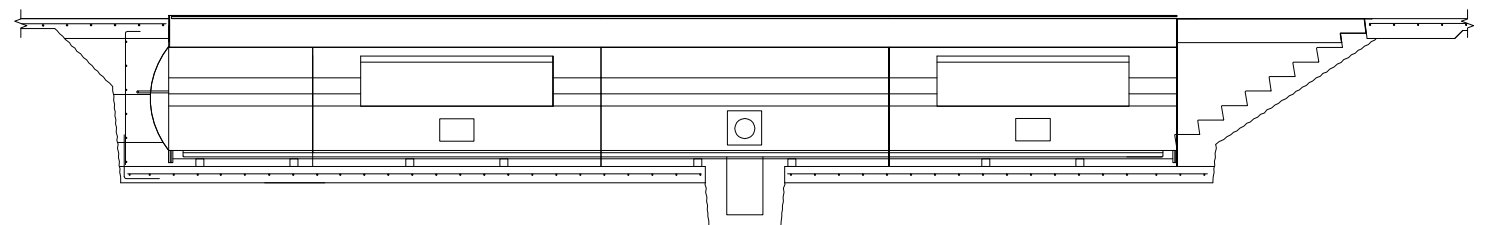

**42' IN-LINE LONGITUDINAL SECTION**  
 $\frac{1}{4}'' = 1'-0''$

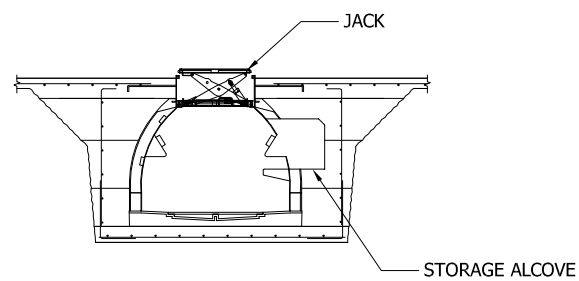

**SERVICE BAY SECTION**  
 $\frac{1}{4}'' = 1'-0''$  AT STORAGE ALCOVE

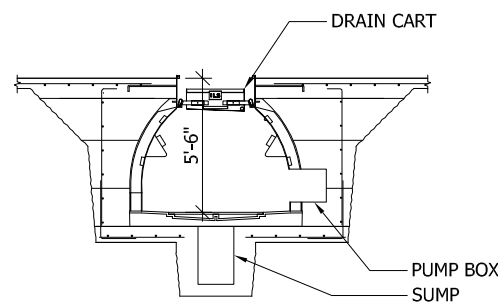

**SERVICE BAY SECTION**  
 $\frac{1}{4}'' = 1'-0''$  AT PUMP BOX

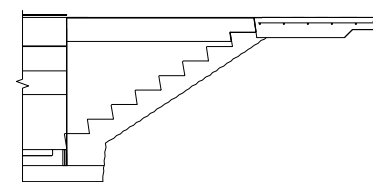

**IN-LINE STAIR SECTION**  
 $\frac{1}{4}'' = 1'-0''$

- NOTES:
1. SERVICE BAY MODULES HAVE A STANDARD LENGTH OF 12'-0".
  2. NON-STANDARD DIMENSIONS ARE EASILY ACCOMODATED.
  3. ENVIROLUBE IS SUITABLE FOR NEW CONSTRUCTION AND RETRO-FIT APPLICATIONS.
  4. CONTACT ILS ENGINEERING (541-517-1393) FOR COMPLIMENTARY PRE-DESIGN SERVICES.

\* THIS SHEET WAS DRAWN 34"x22", NOT TO SCALE IF REDUCED

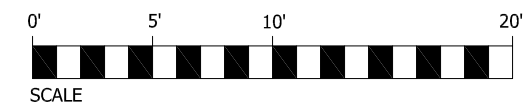

© 2014 INTEGRATED LUBE SERVICE, INC

REVISIONS		
NO.	DATE	REMARKS

DESIGNED BY  
JERRY STEELE  
 DRAFTED BY  
MARTY VAUGHN  
 CHECKED BY  
MARK RICHARDS

**EXAMPLE DRAWINGS  
 AUTOMOTIVE OPTIONS  
 36' & 42' IN-LINE UNITS**



PO BOX 3227 - GRASS VALLEY - CA - 95945  
 800-700-3309

36' AND 42' IN-LINE UNITS



DATE 05/20/2014

SHEET NO.

**EL2**